

**• General Description**

The ZM160N04D combines trench MOSFET technology with a low resistance package to provide extremely low  $R_{DS(ON)}$ . This device is ideal for load switch and battery protection applications.

**• Features**

- Advance high cell density Trench technology
- Low  $R_{DS(ON)}$  to minimize conductive loss
- Low Gate Charge for fast switching
- Low Thermal resistance

**• Application**

- MB/VGA Vcore
- SMPS 2<sup>nd</sup> Synchronous Rectifier
- POL application
- BLDC Motor driver

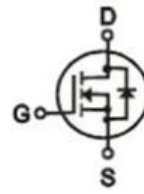
**• Product Summary**

$V_{DS}=40V$

$R_{DS(ON)} = 18m\Omega$

$I_D=35A$

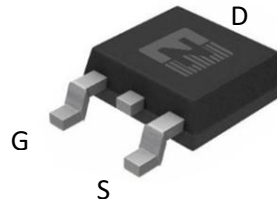

TO-252

**• Ordering Information:**

Part NO.	ZM160N04D
Marking	ZM160N04
Packing Information	REEL TAPE
Basic ordering unit (pcs)	2500

**• Absolute Maximum Ratings ( $T_C = 25^\circ C$ )**

Parameter	Symbol	Rating	Unit
Drain-Source Voltage	$V_{DS}$	40	V
Gate-Source Voltage	$V_{GS}$	$\pm 20$	V
Continuous Drain Current	$I_{D@TC=25^\circ C}$	35	A
	$I_{D@TC=75^\circ C}$	26.6	A
	$I_{D@TC=100^\circ C}$	22.1	A
Pulsed Drain Current <sup>①</sup>	$I_{DM}$	80	A
Total Power Dissipation	$P_D@TC=25^\circ C$	85	W
Total Power Dissipation	$P_D@TA=25^\circ C$	3.5	W
Operating Junction Temperature	$T_J$	-55 to 150	$^\circ C$
Storage Temperature	$T_{STG}$	-55 to 150	$^\circ C$

**•Thermal resistance**

Parameter	Symbol	Min.	Typ.	Max.	Unit
Thermal resistance, junction - case	$R_{thJC}$	-	-	1.5	°C/W
Thermal resistance, junction - ambient	$R_{thJA}$	-	-	35	°C/W
Soldering temperature, wave soldering for 10s	$T_{sold}$	-	-	265	°C

**•Electronic Characteristics**

Parameter	Symbol	Condition	Min.	Typ	Max.	Unit
Drain-Source Breakdown Voltage	$BV_{DSS}$	$V_{GS} = 0V, I_D = 250\mu A$	40			V
Gate Threshold Voltage	$V_{GS(TH)}$	$V_{GS} = V_{DS}, I_D = 250\mu A$	1.2		2.5	V
Drain-Source Leakage Current	$I_{DSS}$	$V_{DS} = 40V, V_{GS} = 0V$			1.0	$\mu A$
Gate- Source Leakage Current	$I_{GSS}$	$V_{GS} = \pm 20V, V_{DS} = 0V$			$\pm 100$	nA
Static Drain-source On Resistance	$R_{DS(ON)}$	$V_{GS} = 10V, I_D = 10A$		18	23	m $\Omega$
		$V_{GS} = 4.5V, I_D = 10A$		23	30	m $\Omega$
Forward Trans conductance	$g_{FS}$	$V_{DS} = 10V, I_D = 10A$		4.5		S
Source-drain voltage	$V_{SD}$	$I_S = 10A$			1.28	V

**•Dynamic Characteristics**

Parameter	Symbol	Condition	Min.	Typ	Max.	Unit
Input capacitance	$C_{iss}$	$V_{GS} = 0V, V_{DS} = 25V$ $f = 1MHz$	-	805	-	pF
Output capacitance	$C_{oss}$		-	94	-	
Reverse transfer capacitance	$C_{rss}$		-	58	-	
Total gate charge	$Q_g$	$V_{DD} = 25V$ $I_D = 25A$ $V_{GS} = 10V$	-	12	-	nC
Gate - Source charge	$Q_{gs}$		-	3.1	-	
Gate - Drain charge	$Q_{gd}$		-	2.8	-	
Turn-ON Delay time	$t_{D(on)}$	$V_{GS} = 10V, V_{DS} = 15V$ $R_G = 3\Omega, R_L = 2.5\Omega$		3		ns
Turn-ON Rise time	$t_r$			4		ns
Turn-Off Delay time	$t_{D(off)}$			15		ns
Turn-Off Fall time	$t_f$			2		ns
Reverse Recovery Time	$t_{RR}$	$V_{DD} = 20V, dI_S/dt = 100A/\mu s, I_S = 8A$		12		ns
Reverse Recovery Charge	$Q_{RR}$			3.5		nC

Note: ① Pulse Test : Pulse width  $\leq 300\mu\text{s}$ , Duty cycle  $\leq 2\%$  ;

Fig.1 Power Dissipation

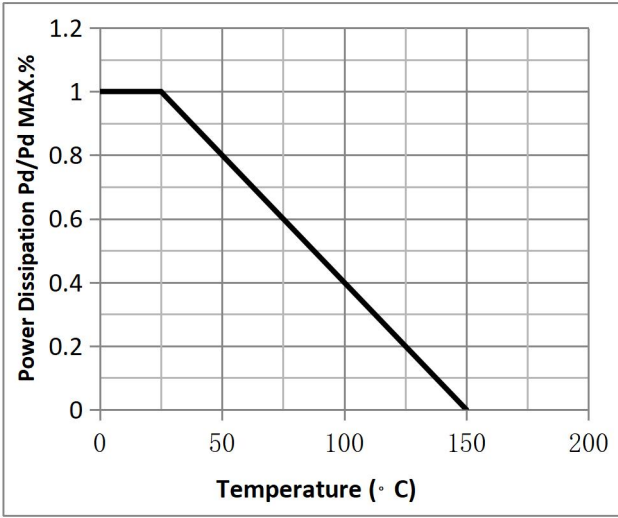

Fig.2 Typical output Characteristics

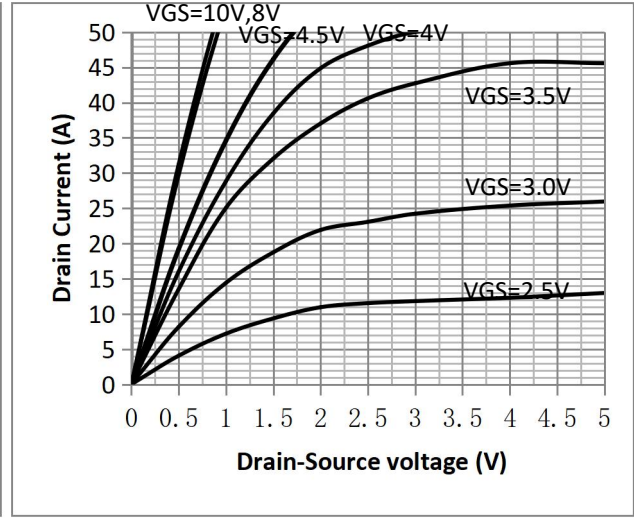

Fig.3 Gate-Charge Characteristics

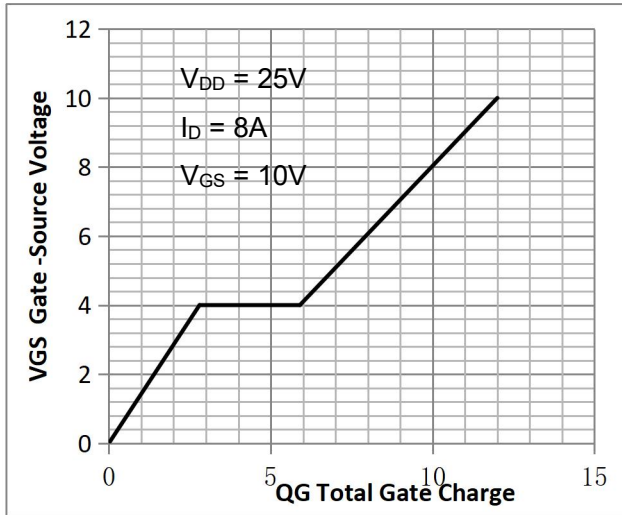

Fig.4 Capacitance Characteristics

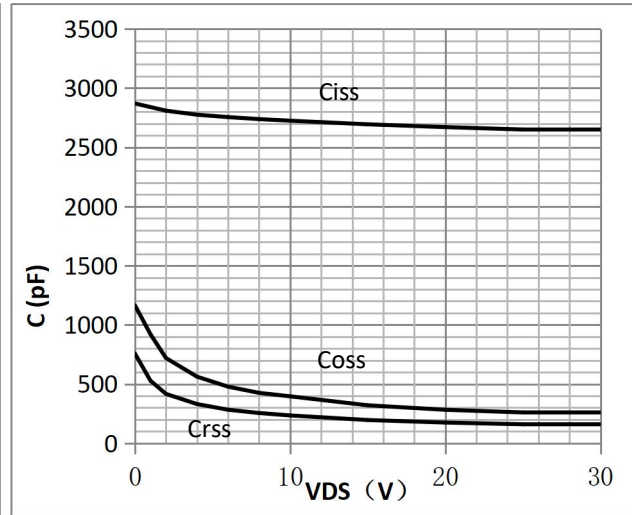

Fig.5 Threshold Voltage V.S Junction Temperature

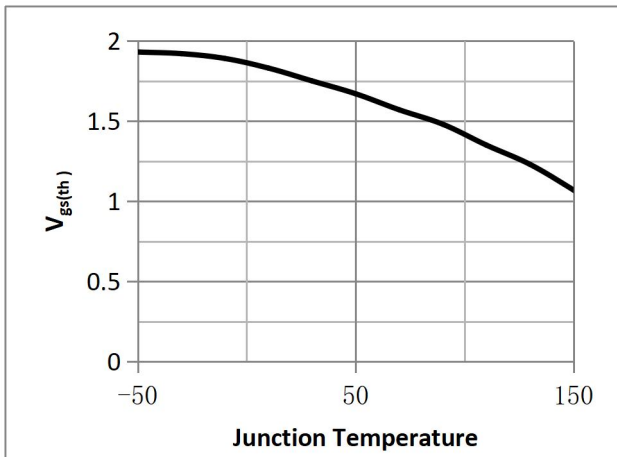

Fig.6 Resistance V.S Drain Current

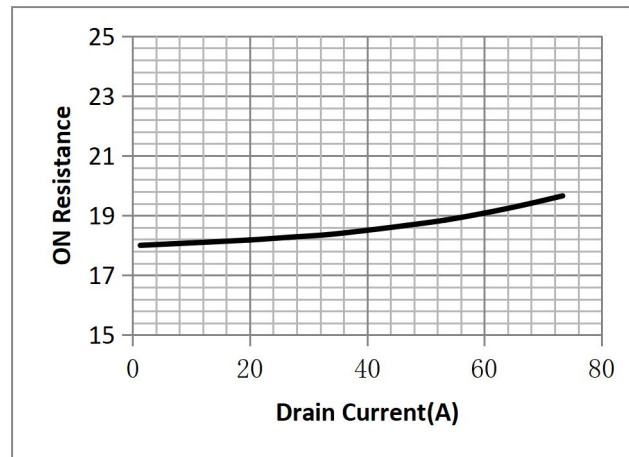

Fig.7 On-Resistance VS Gate Source Voltage

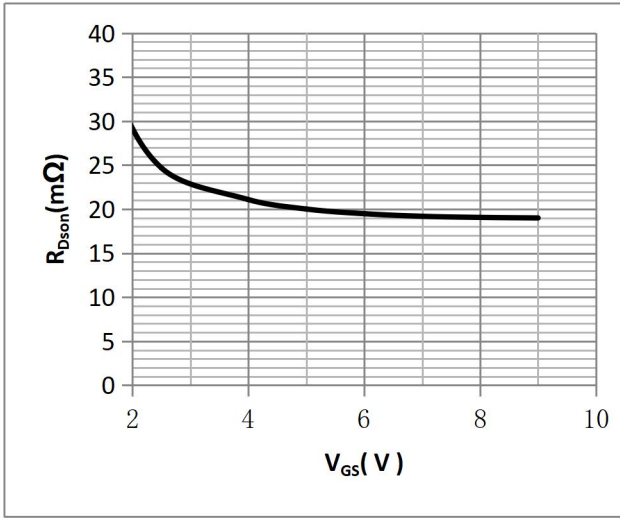

Fig.8 On-Resistance V.S Junction Temperature

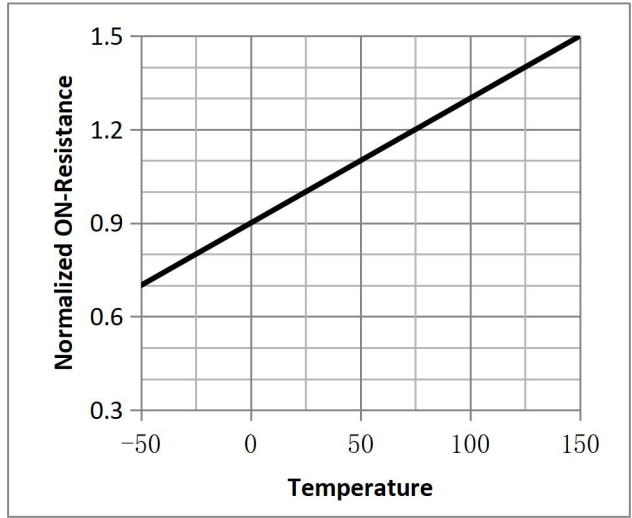

Fig.9 SOA Maximum Safe Operating Area

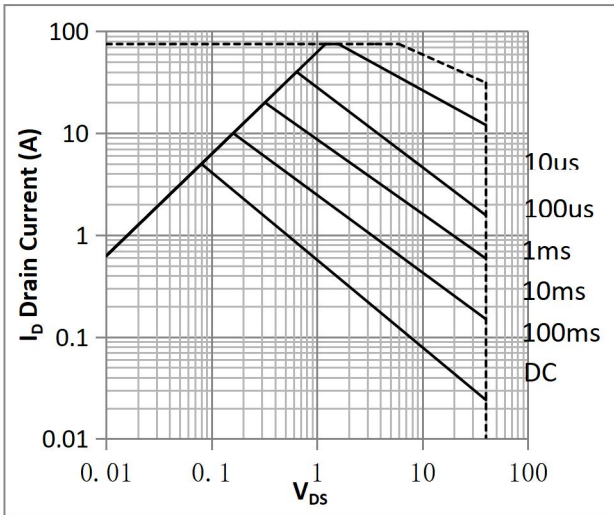

Fig.10  $I_D$ -Junction Temperature

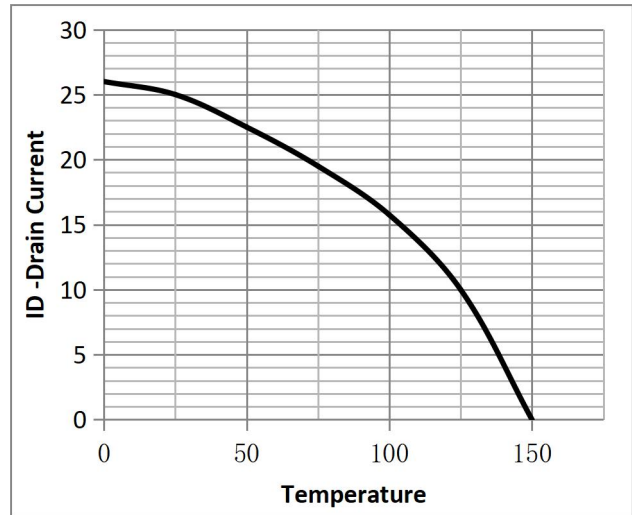

Figure.11 Diode Forward Voltage vs. Current

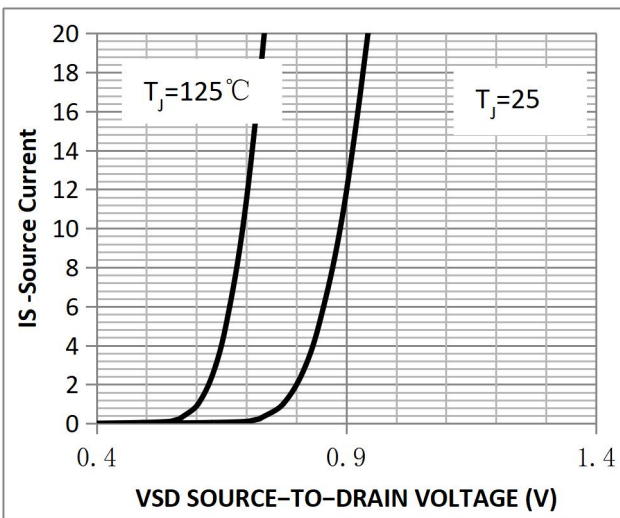

Figure.12 Transfer Characteristics

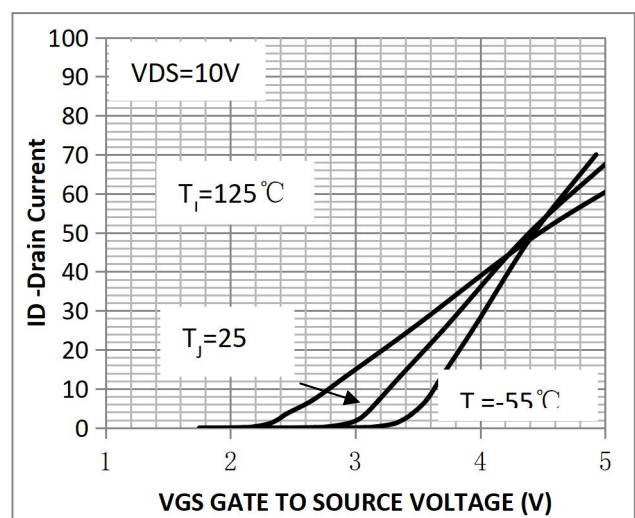

Fig.13 Switching Time Measurement Circuit

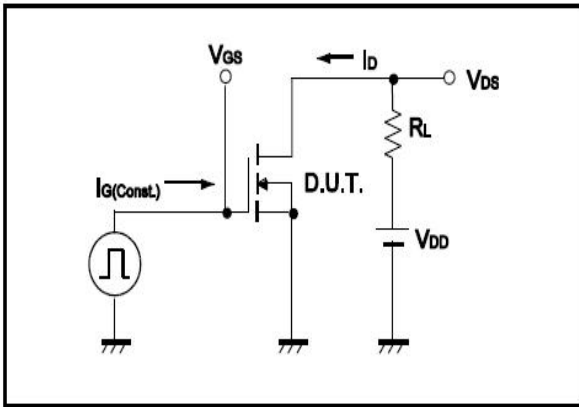

Fig.14 Gate Charge Waveform

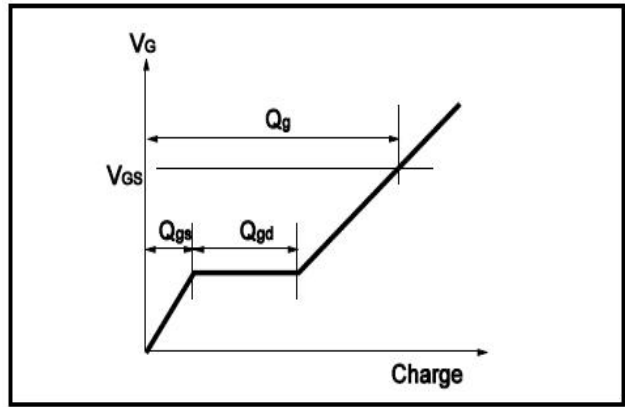

Fig.15 Switching Time Measurement Circuit

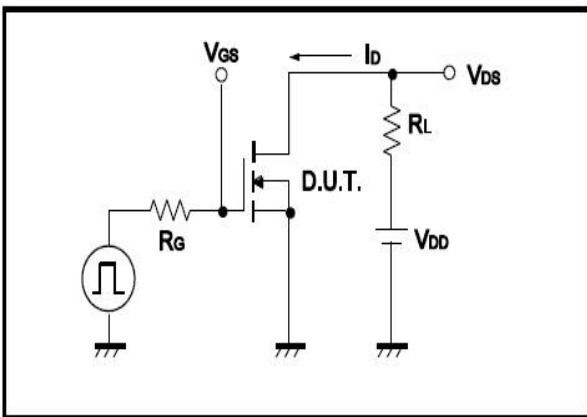

Fig.16 Gate Charge Waveform

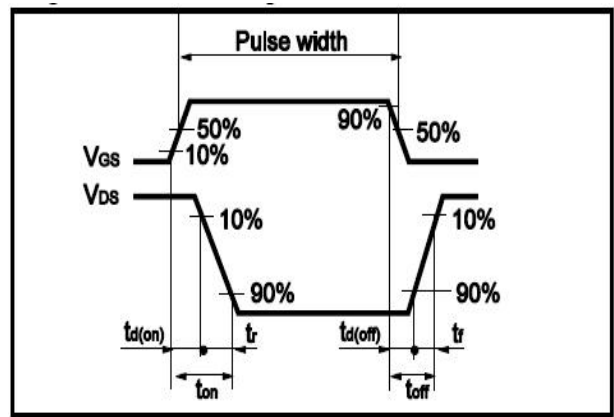

Fig.17 Avalanche Measurement Circuit

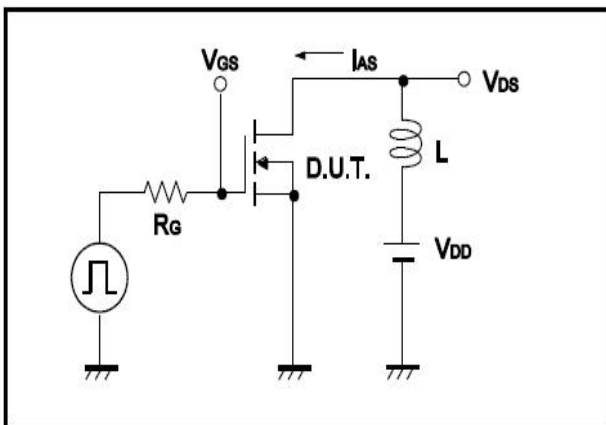
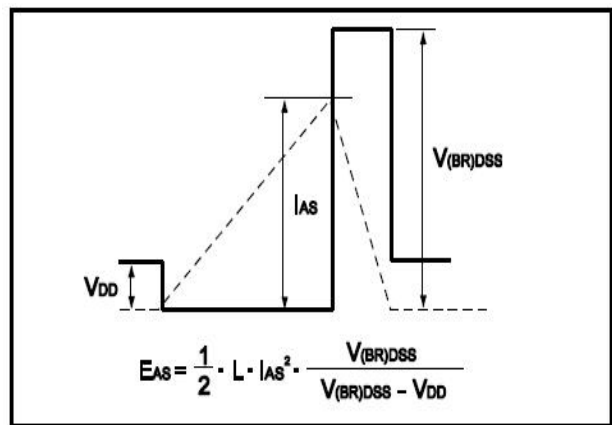

Fig.18 Avalanche Waveform



•Dimensions (TO-252)

Unit: mm

SYMBOL	min	max	SYMBOL	min	max
A	2.10	2.50	B	0.85	1.25
b	0.50	0.80	b1	0.50	0.90
b2	0.45	0.70	C	0.45	0.70
D	6.30	6.75	D1	5.10	5.50
E	5.30	6.30	e1	2.25	2.35
L1	9.20	10.60	e2	4.45	4.75
L2	0.90	1.75	L3	0.60	1.10
K	0.00	0.23			

